

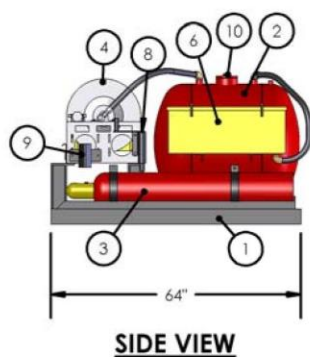

Quality is Behind the Diamond.

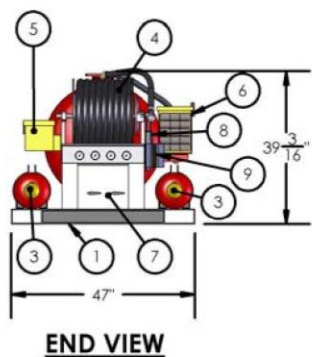
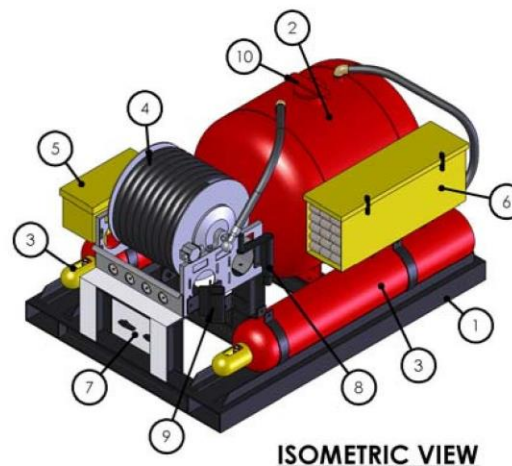
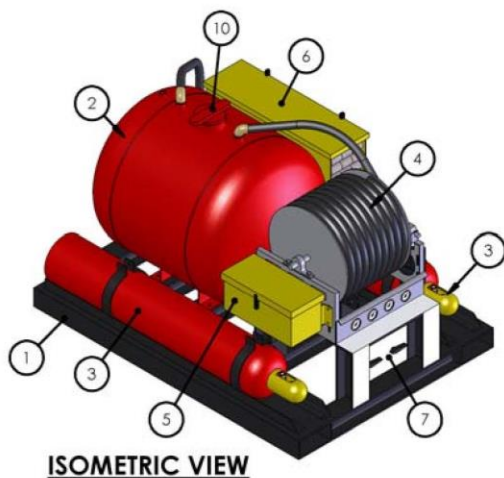
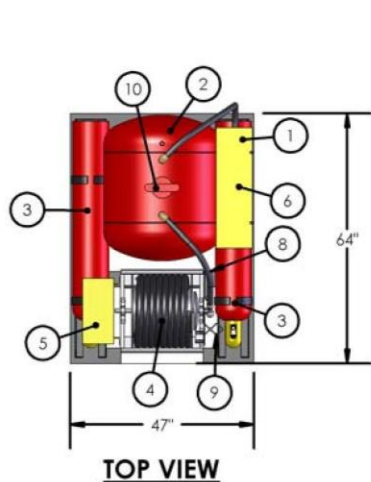

**AMEREX MODEL 967**  
**100 Gallon CAFS Unit**

Empty Weight - 1,026 lbs.

Full Weight - 1,859 lbs.

ITEM No.	UNIT DESCRIPTION
1	ALUMINUM SKID W/ COMMERCIAL FORKFIIT CAPABILITIES
2	100 GALLON CAFS VESSEL
3	CAFS 2-300 CF EXPELLANT BOTTLE - ONE OPTIONAL
4	HOSE REEL W/ 100 FT. 1" HOSE WITH SHUTOFF & TIP
5	TOOL BOX
6	HOSE STORAGE BOX W/ 100 FT 1/2" HOSE W/ SHUTOFF AND TIP - OPTIONAL
7	CONTROL PANEL
8	REEL CRANK
9	SHUTOFF HOLDER
10	FILL CAP