

BRACKETS

All Amerex brackets meet the latest UL salt spray requirements (240 hrs. @ 20% salt solution—ASTM B117). 1-year manufacturer's warranty applies to all brackets. Please see Amerex Parts Catalog for bracket details.

Wall-Hanger Brackets

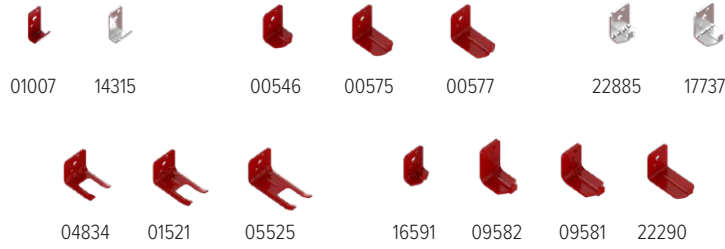

6- & 10-lb. Wall Strap Type



Vehicle/Marine/Aviation Brackets



Heavy-Duty Box-Type Vehicle Brackets (Red Brackets are Galvanized)

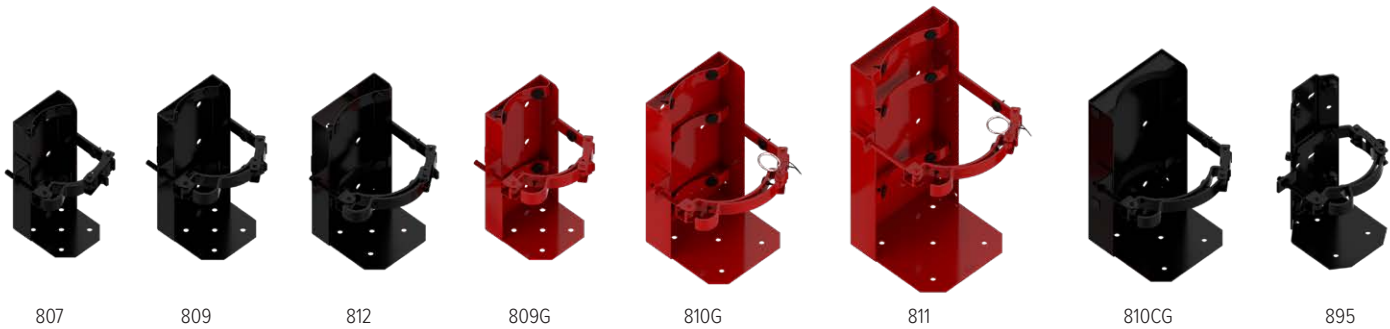

Heavy-Duty Dolly Cart



Heavy-Duty Rubber Strap Brackets

