



INTRODUCTION

The principles and procedures contained in this manual are intended for the recharging and agent reclaim associated with the servicing of Amerex Halotron I hand portable/wheeled fire extinguishers. They are intended for qualified service agencies using the Amerex PN 14538 Halotron Recharge Kit and one of the Amerex Charge Cylinders (Model 891 - 80 lb or Model 892 - 200 lb) and/or one of the Amerex Reclaim Cylinders (PN 16861 - 80 lb or PN 09789 - 200 lb). The process of recharging fire extinguishers with Halotron I involves working with a pressurized liquid and high pressure gas, so it should only be undertaken by trained personnel.

It is recognized that most fire extinguisher service technicians will have had prior experience servicing Halon 1211 extinguishers. While the procedures for Halotron I are similar in most respects, there are two main differences: the type of elastomers (collar o-rings, valve stem seals) and the use of argon (instead of nitrogen) for pressurization. The elastomers used with Halon 1211 (or dry chemical) are not compatible with Halotron I. Chloroprene based or EPDM rubber is used in all Amerex o-rings, valve stem seals and recharge kit seals. If incompatible elastomers are used, the result can be loss of extinguisher pressure or blockage of the valve preventing proper discharge.

Extinguisher performance is enhanced and required cylinder volume is reduced by pressurizing extinguishers with argon, which is more soluble in Halotron I than nitrogen. As the extinguisher discharges and the extinguisher's internal pressure drops, argon in solution will move from the Halotron I liquid into the vapor space. This transfer of argon from the liquid to the vapor space helps maintain a higher and more even pressure throughout the extinguisher discharge, especially at cold temperatures. **NITROGEN SHALL NOT BE USED TO PRESSURIZE HALOTRON I EXTINGUISHERS OR CHARGE CYLINDERS.**

SAFETY PRECAUTIONS

The process of recharging extinguishers and reclaim cylinders with Halotron I (sometimes referred to as HCFC Blend B or Halotron I Pre-Sat Base) involves the use of a pressurized liquid and high pressure gas. The process shall only be undertaken by personnel trained in the use of these kinds of materials. High pressure (compressed) gases can be extremely dangerous if not handled properly. Improperly installed or maintained pressure regulators or hose assemblies can cause system failures and result in possible personal injury. Follow the instructions precisely for the installation of these components.

A. Chemical Hazards

The primary component of Halotron I is HCFC-123 (2,2-dichloro-1, 1, 1-trifluoromethane). Toxicologically, this chemical has been widely studied. The LC₅₀ (4 hr., rats) has been determined to be between 2.8 and 3.2% by volume. The cardiotoxic LOAEL (lowest observable adverse effect level) is 2% by volume. The NOAEL (no adverse effect level) is 1% by volume. HCFC-123 is relatively non-toxic, however, all measures shall be taken to minimize inhalation of any vapors.

The primary hazard associated with argon used for extinguisher pressurization is its ability to function as a simple asphyxiant (i.e. to displace oxygen). **RECHARGING OPERATIONS SHALL BE CONDUCTED IN A WELL VENTILATED ENVIRONMENT.**

B. Personal Protective Equipment

To insure proper protection, it is recommended that standard equipment for handling compressed gases and refrigerants be used for recharging operations. This would include the use of rubber gloves and eye goggles.

All containers (including high pressure gas cylinders) used in recharging operations shall be secured to stationary objects to prevent uncontrolled movement.

- C. It is recommended that persons involved in recharging operations refrain from smoking.
- D. Consult the Halotron I Safety Data Sheet (SDS) for more safety information. The “Halotron I Health and Toxicity Summary Bulletin” should also be consulted for additional information.

RECHARGING/AGENT RECLAIM PRINCIPLES

It is imperative that before performing recharging or agent reclaim procedures, the following guidelines are followed:

1. All of the Maintenance Procedures detailed in Amerex PN 14425 portables or PN 16672 wheeled Owner’s Service Manual be completed.
2. All extinguisher components and recharging equipment components are compatible for use with Halotron I.

Extinguisher recharging/agent reclaim shall be performed only by trained technicians. Amerex parts and service equipment shall be used in the performance of these procedures. Contact Amerex Corporation if you have any questions regarding parts, recharging equipment, hydrostatic testing or need for any specialized tools.

All equipment shall be maintained dry and free of moisture. Purging all lines with argon each time the recharging apparatus has been exposed to air will help minimize the amount of moisture that can gain entry to the system.

The general recharging procedure follows three basic steps:

1. Extinguisher evacuation
2. Halotron I recharging (liquid transfer)
3. Extinguisher final pressurization

A. Evacuation Principals

Extinguishers may be evacuated one at a time, or in groups through the use of a manifold system. Cylinder evacuation prior to recharging is strongly recommended for two reasons.

1. To remove moist air from the cylinder, which if present can cause corrosion.
2. To accelerate the recharging process by removing some of the back pressure that results from entrapped air.

The vacuum pump selected shall be capable of pulling a minimum vacuum of 27 inches (686 mm) mercury (at sea level).

B. Halotron I Recharging (Liquid Transfer) Principals

Once the extinguisher has been vacuumed, it is ready to be filled with Halotron I (sometimes referred to as HCFC Blend B or Halotron I Pre-Sat Base). The recharging lines and quick connect used in the recharging process shall be compatible with Halotron I. Elastomers shall be Chloroprene based on EPDM rubber.

One of the key differences between Halon 1211 and Halotron I is that the Halotron I supply cylinder must be kept under pressure during the transfer of liquid from the supply cylinder to an extinguisher. Halotron I is a blend of two gases forced into a base of HCFC-123 by pressure. To insure that the uniformity of the Halotron I blend stays consistent during transfer, a supply of argon must be connected to the Halotron I supply cylinder to maintain a minimum pressure of 95 psi (655 kPa). This is easily accomplished with a high pressure argon cylinder and a regulator.

No pumps are necessary to transfer the Halotron I liquid into the extinguishers. The transfer can be completed by connecting the recharging hose to the extinguisher and opening the extinguisher valve. Once the extinguisher valve is opened, the pressure difference will allow the Halotron I to fill the extinguisher. Once the desired Halotron I weight is reached, the extinguisher valve can be closed.

C. Final Pressurization Principals

The pressurizing gas for Halotron I is argon and shall conform to the specification in Figure A. Argon is somewhat soluble in Halotron I. When an extinguisher is discharged, the argon in solution is released into the extinguisher vapor space, helping to maintain the pressure. Since nitrogen is considerably less soluble in Halotron I, it shall **NEVER** be used to pressure Halotron I. Pressurization with nitrogen could cause a decrease in the performance of the extinguisher.

ARGON SPECIFICATIONS

The final pressurization of an extinguisher is accomplished by:

1. Pressurizing the extinguisher with argon to the desired pressure.
2. Agitating the extinguisher until the pressure equalizes.
3. Repeating Steps 1 and 2 until pressure stabilizes at the correct operating pressure.

Property	Minimum	Maximum
Assay	99.998%	---
Oxygen		4.0 ppm
Total Hydrocarbons	---	0.5 ppm
Water	---	4 ppm
Dew Point	---	-90°F (-68°C)

The agitation of the extinguisher aids in the absorption of argon into the Halotron I liquid. The agitation does not have to be vigorous but can be accomplished by a gentle rocking of the extinguisher for 5 to 10 seconds. It is not uncommon for the extinguisher to drop more than 20 or 30 psi (38 kPa to 207 kPa) the first time it is agitated.

Figure A

Depending on the temperature when recharging the Extinguisher, it may be necessary to adjust the final pressure. See temperature vs. pressure charts below.

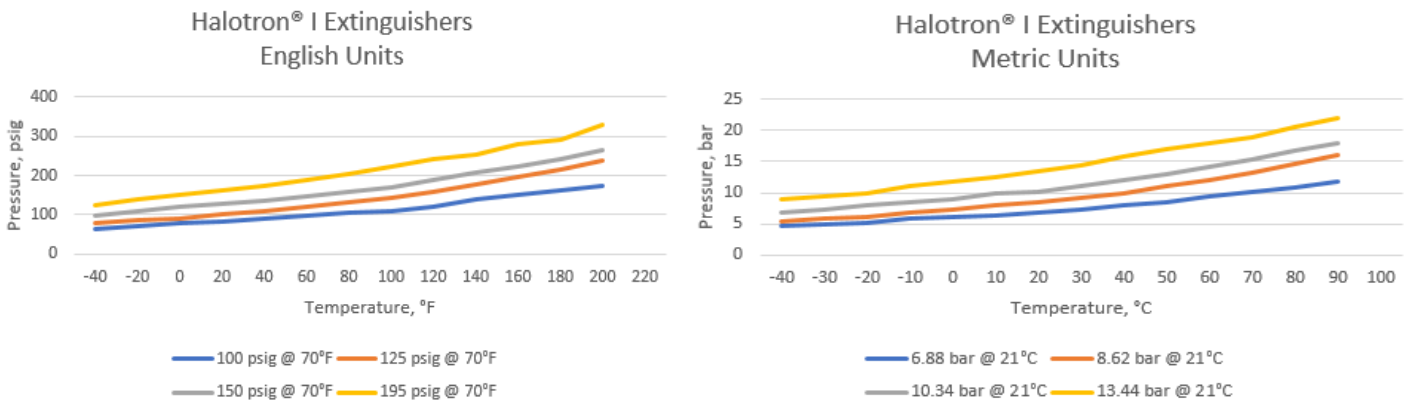

D. Agent Reclaim Principals:

Halotron I shall always be stored and transferred under pressure to ensure that the inert gases in the blend are not released. The Halotron I agent in the extinguisher can be transferred to a reclaim cylinder either by a pump or by using pressure differentials. If using a pump, ensure that all pump materials and seals are compatible with Halotron I.

Generally, there are four steps to this transfer when not using a pump:

1. Connect the extinguisher to the line leading to the reclaim cylinder liquid valve.
2. Open the extinguisher valve to allow the liquid from the extinguisher to transfer to the reclaim cylinder (because of back-pressure, not all liquid will transfer).
3. Re-pressurize the extinguisher to operating pressure with argon (flip valve allows this to be accomplished without disconnecting the extinguisher from the line to the reclaim cylinder).
4. Repeat Steps 2 and 3 until no more liquid will transfer from the extinguisher (usually 1-2 times).

When the transfer is complete, the extinguisher can be vented and serviced according to the step by step procedure of the Owner's Service Manuals. There will be a small amount of residual Halotron I left in the extinguisher which will evaporate when the extinguisher is opened. Agent reclaim shall be performed in a well-ventilated area to prevent vapor accumulation.

After servicing has been completed and the extinguisher is ready to be refilled, the reclaim cylinder can be treated as any other Halotron I charge cylinder. Refill the extinguisher according to the step by step procedure. Between each extinguisher service, the reclaim cylinder shall be vented down to approximately 5 psi (34 kPa). By venting to this minimal pressure, a small liquid heal will remain (minimizing further heal loss) and the positive pressure will ensure that no contaminants enter the cylinder.

Prior to the first time use of a reclaim cylinder, the cylinder shall be internally inspected for cleanliness and then vacuumed to a minimum of 27 inches (686 mm) mercury (at sea level).

AMEREX PN 14538, HALOTRON I RECHARGE KIT

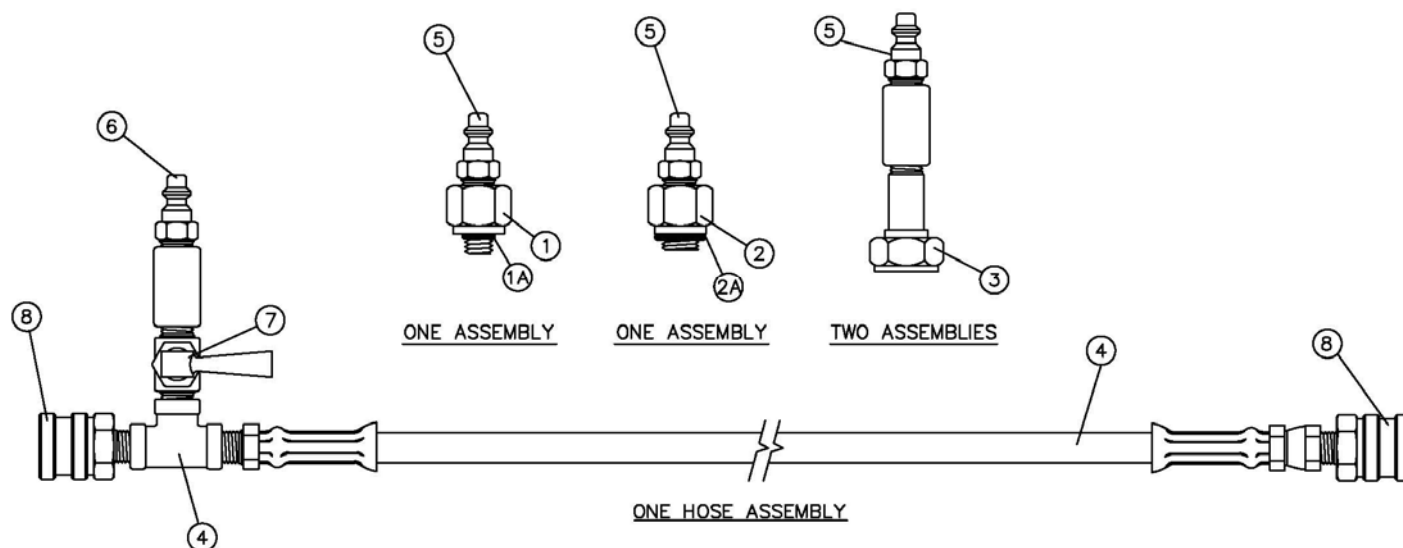

AMEREX PN 14538 HALOTRON I RECHARGE KIT			
Item No.	Part No.	Description	Quantity Included in Kit
1	14569	Fill Adapter – Aluminum Valve	1
1A	01532	Hose/Nozzle Gasket (o-ring)	1
2	14568	Fill Adapter – Brass Valve	1
2A	06978	Hose Gasket – Brass Valve	1
3	14648	CGA Fill Adapter Assembly	2
4	14537	Hose Assembly (6 ft.)	1
5	14536	Adapter “Quick Connect” Male (Fill Adapters)	4
6	01406	Adapter “Quick Connect” Male (Recharge Hose Assembly)	1
7	01733	Toggle Valve	1
8	14535	Adapter “Quick Connect” Female	2

HALOTRON I RECLAIM USING Amerex PN 16861 - 80 lb or 09789 – 200 lb Reclaim Cylinder & PN 14538 Halotron I Recharge Kit

NOTE: In order that a partially discharged or leaking Halotron I extinguisher may be properly serviced and recharged, it will be necessary to have a Reclaim Cylinder (either empty or with sufficient capacity to void the extinguisher of remaining Halotron I). The PN 16861 - 80 lb or 09789 – 200 lb capacity Reclaim Cylinders are ideal for this purpose.

TRANSFER TO RECLAIM CYLINDER

1. Confirm that the hoses and components are clean and free of debris. Purge all hoses with argon. Check for leaks and repair if necessary.
2. Ensure that the reclaim cylinder is ready for the liquid transfer. It shall be either under a vacuum or have a minimal pressure, about 5 psi (34 kPa).
3. Starting with all valves closed, connect the recharging hose female quick connect (toggle valve end) to the extinguisher fill adapter male quick connect.
4. Connect the recharging hose female quick connect that is installed on the liquid outlet of the extinguisher to the fill adapter male quick connect of the reclaim cylinder.
5. Connect the argon gas supply hose female quick connect to the toggle valve male quick connect.
6. Adjust the toggle valve to direct the flow from the extinguisher to the reclaim cylinder.
7. Set the argon supply regulator to 0 psi (0 kPa) and then open the argon cylinder valve.
8. Set the argon regulator to the extinguisher operating pressure and open the toggle valve. Depress extinguisher operating lever – this will pressurize the extinguisher. After operating pressure is reached, release the operating lever and close the toggle valve.
9. Open the reclaim cylinder valve, liquid outlet handwheel.
10. Open extinguisher valve (depress operating lever) to allow the extinguisher contents to flow into the reclaim cylinder.
11. After the flow has stopped, close the extinguisher valve (release operating lever). Close the reclaim cylinder valve, liquid outlet handwheel.
12. Open the toggle valve to allow the flow of additional argon to repressurize the extinguisher.
13. Open the extinguisher valve (depress lever) and re-pressurize the extinguisher with argon to its operating pressure.
14. Close the toggle valve, open the reclaim cylinder valve, liquid outlet handwheel and open the extinguisher valve (depress lever).
15. After the flow has stopped, close the extinguisher valve (release lever). Close the reclaim cylinder valve, liquid outlet handwheel.
16. If there is still appreciable liquid in the extinguisher, repeat Steps 12 through 15 as necessary.
17. Make sure that your area is well ventilated and vent the remaining contents of the extinguisher and perform the maintenance procedures detailed in PN 14425 portables or PN 16672 wheeled Owner's Service Manual prior to recharging the extinguisher.

RECHARGING (LIQUID TRANSFER) OF HALOTRON I EXTINGUISHERS

Using Amerex Halotron I supply cylinders Models 891 (80 lb) or 892 (200 lb) and PN 14538 Halotron I Recharge Kit

SET UP INSTRUCTIONS

1. Attach fill adapters PN 14648 (2 supplied) to the supply cylinder valve, liquid and vapor outlets.
2. Confirm that all hoses and components are clean and free of debris. Purge all hoses with argon. Check for leaks and repair if necessary.
3. Install female quick connect end of recharging hose assembly with toggle valve to the fill adapter on liquid outlet.
4. Connect the argon supply line quick connect to the vapor outlet quick connect on the supply cylinder.

NOTE: It is very important that supply cylinder pressure be maintained at a minimum of 100 PSI (689 kPa) throughout the recharging process using a constant flow of argon.

RECHARGING (LIQUID TRANSFER) OF AN EMPTY HALOTRON I EXTINGUISHER

1. EXTINGUISHER TO BE REFILLED MUST BE PROPERLY SERVICED AND A NEW O-RING AND VALVE STEM ASSEMBLY INSTALLED (see Amerex parts book PN 27277). The extinguisher cylinder interior must be clean and dry.
2. Connect the empty extinguisher to a vacuum pump. Open extinguisher valve (depress operating level) and evacuate the extinguisher to approximately 27 inches (at sea level). Close extinguisher valve (release operating lever) and disconnect from the vacuum pump.
3. Install proper Halotron I fill adapter to extinguisher (see parts list page 4).
4. Connect the Argon supply to the vapor outlet of the supply cylinder. Starting with all valves closed, set the argon regulator at 0 psi (0 kPa) and then open the argon cylinder valve. Set the regulator to 100 psi (689 kPa). Verify the correct pressure on the pressure gauge and adjust as necessary.
5. Completely open the supply cylinder valve vapor outlet and let the cylinder pressure stabilize for one minute before proceeding to the next step. This valve vapor outlet is to remain open during the entire liquid transfer.
6. Connect the recharging hose to the extinguisher fill adapter.
7. Open the cylinder liquid valve on the Model 891 or 892 supply cylinder, recharging the hose with liquid.
8. Place the extinguisher on an accurate scale.
9. Tare weight (zero) the scale. This will take into account the liquid now in the hose and the net weight transferred will be indicated.
10. Open the extinguisher valve (depress operating lever) and allow liquid transfer into the extinguisher until the desired weight is achieved as determined by the scale.
11. When the desired liquid weight is reached, close the extinguisher valve (release lever) and close the Halotron I charge cylinder liquid valve.
12. Close the charge cylinder vapor valve and the argon supply cylinder valve.
13. Open the argon gas hose vent (if one is installed) to relieve pressure in the gas hose.
14. Disconnect the argon gas hose quick connect from the charge cylinder vapor valve quick connect.
15. Proceed with final pressurization – page 7.

FINAL PRESSURIZATION OF HALOTRON I EXTINGUISHERS USING Amerex Models 891 (80 lb.) and 892 (200 lb.) Halotron I Charge Cylinders and PN 14538 Halotron I Recharge Kit

FINAL PRESSURIZATION PROCEDURE

1. Confirm that the hoses and components are clean and free of debris. Purge all hoses with argon. Check for leaks and repair if necessary.
2. Start with all valves closed, connect the argon gas supply cylinder female quick connect to the extinguisher fill adapter male quick connect.
3. Set the regulator at 0 psi (0 kPa) and open the argon cylinder valve.
4. Open the argon gas cylinder valve and set the regulator to the extinguisher operating pressure. If the temperature range is not in the range of 70 ± 5 °F, consult the pressure/temperature chart on page 3 for the correct temperature/pressure adjustment. Verify the correct pressure on the pressure gauge and adjust as needed.
5. Open the extinguisher valve (depress lever) and allow argon gas to transfer into the extinguisher until the pressure equalizes.
6. Close the extinguisher valve (release lever) and agitate the extinguisher by vigorously rocking it back and forth for 5 to 10 seconds.
Note: A large amount of argon will be absorbed into the Halotron. It is very important that the extinguisher be rocked well to allow this absorption.
7. Repeat steps 5 and 6 until the extinguisher pressure equalizes at the correct operating pressure for the extinguisher. This will normally require 2 or 3 repetitions.
8. Close the argon supply valve and then open the argon supply hose vent (if one is installed) to relieve the pressure in the hoses.
9. Disconnect the argon supply hose quick connect from the extinguisher adapter. Remove the extinguisher adapter.
10. Install pull pin and tamper seal.
11. Install nozzle or hose assembly and recharge tag.
12. Hold extinguisher for 24 to 48 hours, verify pressure and return to customer.

CAUTION: NEVER LEAVE PRESSURE IN A HOSE (EITHER ARGON SUPPLY OR RECHARGE) FOR A PROLONGED PERIOD OF TIME.

SHUT DOWN INSTRUCTIONS

After following the above procedure, there may be a small amount of Halotron I left in the recharging hose. If it will be more than 8 hours before another extinguisher will be filled, Amerex recommends bleeding this Halotron I off into the atmosphere. The bleed off process will prolong the life of your recharge equipment.

Follow this procedure to remove Halotron I captured in the recharging hose:

1. Make sure that the Halotron I charge cylinder is **CLOSED**.
2. Point the male quick connect plug for the argon supply away from yourself and others and open the toggle valve. A small amount of Halotron I and argon may be discharged. Close the toggle valve. The recharging hose will be empty of Halotron I and argon pressure.

HALOTRON I EXTINGUISHER SERVICE PROCEDURES FOR A Leaking Extinguisher or Charge Cylinder

If an extinguisher is leaking but has not lost substantial pressure, the Halotron I can be reclaimed following the procedures on Page 5 (Halotron I Reclaim). If the extinguisher has lost all or most of the pressure, which would cause a loss of the gases from the Halotron I blend, perform the following:

1. Pressurize the extinguisher with argon before attempting a transfer of the contents into a reclaim cylinder.
2. Reclaim the Halotron I liquid in the extinguisher through the prescribed normal agent reclaim procedures on Page 5 into a Halotron I charge or reclaim cylinder which contains “fresh” Halotron I. There will be enough additional gases in the charge or reclaim cylinder to “reconstitute” the reclaimed Halotron I.

If a charge cylinder is leaking but has not lost substantial pressure, the Halotron I can be transferred to a new cylinder by performing the following:

NOTE: If your Halotron I charge cylinder has lost a substantial amount of pressure or has lost total pressure, please notify Amerex immediately.

Models 891 and 892 – 80 and 200 lb. Halotron I Charge Cylinders

1. Connect the argon supply hose to the vapor valve on the leaking charge cylinder and maintain a constant argon pressure of 100 psi (689 kPa) throughout the transfer.
2. Connect the recharge hose assembly to the liquid supply on the leaking charge cylinder to the liquid supply on a new charge or reclaim cylinder that is under a vacuum.
3. Open the liquid valves on both cylinders to allow the liquid to transfer into the new cylinder.
4. When the liquid transfer is complete, allow the cylinders to equalize pressure at 100 psi (689 kPa) before closing the liquid valves and venting the hose.

**FOR REPLACEMENT PARTS SEE THE AMEREX PORTABLE AND WHEELED
PARTS BOOK PN 27277 AVAILABLE AT <http://www.amerex-fire.com> UNDER
MANUALS OF THE RESOURCE SELECTION.**